

Senninger® Pressure Regulators

Low Pressure - High Performance™

Hunter®

Agricultural Irrigation



WHAT'S INSIDE

PRESSURE REGULATION

■ What is a pressure regulator?	03
■ Why do I need a pressure regulator?	03
■ What causes pressure fluctuations?	04
■ How do pressure regulators work?	04
■ What is a performance curve?	05
■ How does pressure affect flow?	06
■ How to install a pressure regulator	07
■ How long do pressure regulators last?	08
■ What are the main signs of wear?	08
■ How to test pressure regulators	09
■ SennREG™ App	09
■ Pressure Regulation - Dynamic or Static	10
■ Why Senninger pressure regulators?	11
■ How to select a pressure regulator	11

PRESSURE REGULATOR MODELS

■ MPR (Mini Pressure Regulator)	12
■ PRLG (Pressure Regulator Landscape Grade)	14
■ PRL (Pressure Regulator Low Flow)	16
■ PSR™2 (Pivot Special Regulator)	18
■ Filter Regulator (Filter plus PSR2 Pressure Regulator)	20
■ PMR-MF (Pressure-Master Regulator® Medium Flow)	22
■ PR-HF (Pressure Regulator High Flow)	24
■ PRU (Pressure Regulator Ultra)	26
■ PRLV (Pressure Regulating Limit Valve)	28
■ PRXF-LV (Pressure Regulating Extended Flow Limit Valve)	30

PARTNERING TOGETHER

For over 6 decades, Senninger® has been the proud provider of agricultural irrigation products serving farmers and irrigation professionals around the world. To further strengthen our company, Senninger Irrigation will now proudly carry the family name of our parent company, as Hunter Agricultural Irrigation.

What This Means to You:

- Continued high-quality Senninger products
- Growing footprint of facilities and personnel to meet your irrigation needs
- Continued outstanding technical support and customer service
- Enhanced production and automation investments worldwide
- Long term commitment to the agricultural irrigation markets we serve

We're grateful to you, our customers, for your partnership and trust over the years. Your support continues to drive our passion for providing industry-leading products, comprehensive educational programs, and exceptional customer service.

WHAT IS A PRESSURE REGULATOR?

The primary function of a pressure regulator is to maintain an irrigation system's desired performance by controlling excessive and varying inlet pressures to constant outlet pressure.

Proper use of pressure regulators helps maintain the overall efficiency of an irrigation system. Pressure regulators assure good sprinkler performance and can help lower energy costs and save water.

Manufacturers offer several models of pressure regulators to meet various irrigation needs: flow ranges, operating pressure rating, maximum inlet pressure, inlet and outlet connection size, and connection type - NPT, BSPT, and hose connection threads.

WHY DO I NEED A PRESSURE REGULATOR?

Every irrigation system will experience some pressure fluctuation, which also causes unwanted flow deviations. Regulators ensure the sprinklers operate within a specific range of flows and pressures to deliver the intended distribution pattern and application rate. Without regulators, the radius of throw is altered, application rates are not consistent, and uniformity numbers are drastically affected. It may also impact the application of fertilizers, chemicals, and nutrients through the irrigation system.

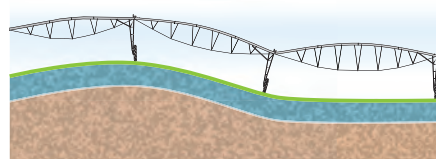

Water Application **With** Pressure Regulators

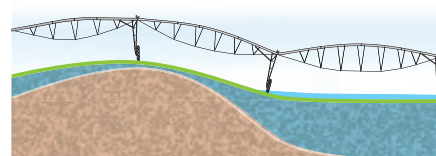

Water Application **Without** Pressure Regulators
Pressure is related to gravity. More pressure is needed to move water uphill. When water moves downhill, more pressure is available.

Every 2.31 ft (0.7 m) of elevation change will result in 1 psi (0.07 bar) pressure change.



WHAT CAUSES PRESSURE FLUCTUATIONS?

Some causes include elevation changes within the irrigated area; pressure loss through pipes and fittings; fluctuations when zones cycle on or off; system demand change on large projects with multiple wells providing water; and activation of end guns and corner arms on mechanized systems.

HOW DO PRESSURE REGULATORS WORK?

Water travels through the inlets of the regulator across a fixed seat into the critical flow area. Water then enters a hollow cylinder or throttling stem attached to a diaphragm. Increasing inlet pressure causes the valve to close. Decreasing inlet pressure allows the valve to open. The regulated outlet pressure is determined by the spring's compressive strength.

WHAT IS A PERFORMANCE CURVE?

Every pressure regulator is designed to operate at a minimum and maximum inlet pressure and a predetermined flow range. A regulator performance curve illustrates how the pressure regulator will perform within the model's range of inlet pressures and flows. The Y-axis shows outlet pressure, and the X-axis shows inlet pressure.

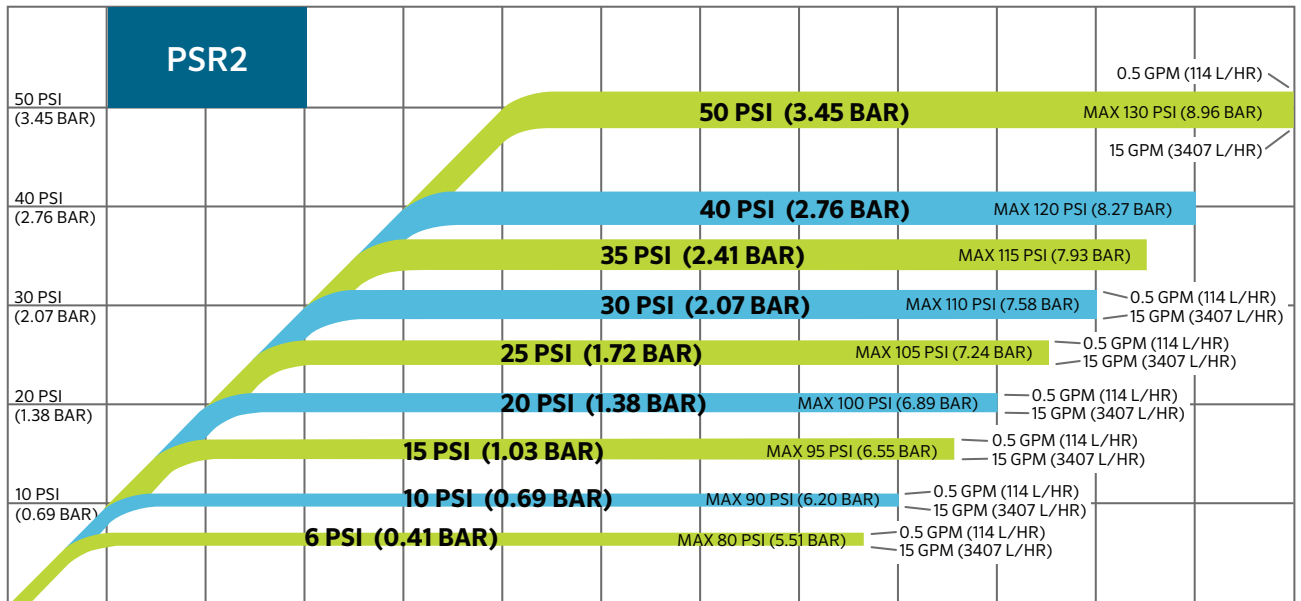

In this chart, the band for the 30 psi (2.07 bar) model shows the performance at various flows. At the lowest flow (0.5 gpm or 114 L/hr), the regulator will maintain an actual outlet pressure slightly higher than 30 psi (2.07 bar). In contrast, at the highest flow (15 gpm or 3407 L/hr), the actual outlet pressure will be slightly lower than 30 psi (2.07 bar)*.

*Source: Rogers, Shaw, Pragada, & Alam, 2010.

HOW DOES PRESSURE AFFECT FLOW?

The operating pressure of an irrigation system always affects the flow rate - $Q = KvP$.

Pressure regulation is particularly important in low-pressure systems, where a slight pressure variation can have a significant impact on the application rate.

Keep in mind that all it takes is a ~20% pressure change to create a ~10% flow variation. The lower a sprinkler's design pressure is, the more critical it is to control pressure to maintain its design flow rate.

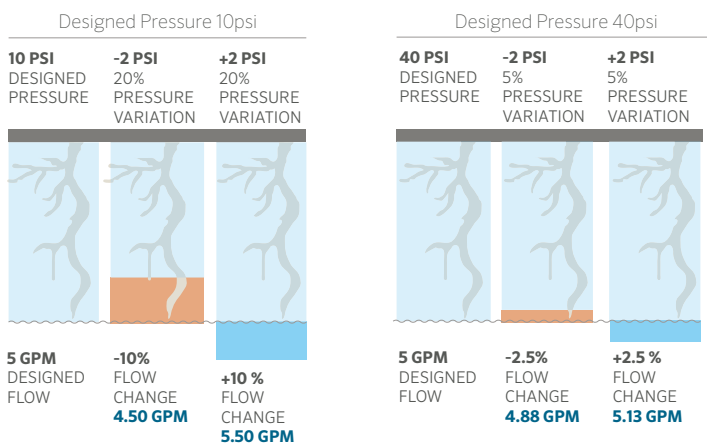

Above left: A pressure variation of 2 psi (0.14 bar) on a sprinkler designed to operate at 10 psi (0.69 bar) is equivalent to a 20% pressure variation. This alters the flow by 10%. Likewise, a sprinkler designed to operate at 5 gpm (1136 L/hr) will have 0.5 gpm (113 L/hr) variation; delivering 4.5 gpm (1022 L/hr) if the pressure decreases and 5.5 gpm (1249 L/hr) if the pressure increases.

Above right: On a sprinkler designed to operate at 40 psi (2.76 bar), the same 2 psi (0.14 bar) variation will only result in a 5% pressure variation. In this case, the fluctuation in flow will be equivalent to a 2.5% change, which is less than a tenth of a gallon per minute. Thus, the flow will oscillate between 4.88 gpm (1108 L/hr) and 5.13 gpm (1165 L/hr).

KEY: ■ Underwatering ■ Overwatering

PRESSURE CHANGE	DESIGN PRESSURE						
	6 psi (0.41 bar)	10 psi (0.69 bar)	15 psi (1.03 bar)	20 psi (1.38 bar)	30 psi (2.07 bar)	40 psi (2.76 bar)	50 psi (3.45 bar)
1 psi (0.069 bar)	16.7	10.0	6.7	5.0	3.3	2.5	2.0
2 psi (0.138 bar)	33.3	20.0	13.3	10.0	6.7	5.0	4.0
3 psi (0.207 bar)	50.0	30.0	20.0	15.0	10.0	7.5	6.0
4 psi (0.276 bar)	66.7	40.0	26.7	20.0	13.3	10.0	8.0
5 psi (0.345 bar)	83.3	50.0	33.3	25.0	16.7	12.5	10.0
6 psi (0.414 bar)	100.0	60.0	40.0	30.0	20.0	15.0	12.0
7 psi (0.483 bar)	N/A	70.0	46.7	35.0	23.3	17.5	14.0
8 psi (0.552 bar)	N/A	80.0	53.3	40.0	26.7	20.0	16.0
Percentage of Pressure Variation (%)							

Pressure regulators are recommended if there is a 20% pressure and/or a 10% flow variation. The lower a system's design pressure, the more critical it is to accurately control its pressure.

HOW TO INSTALL A PRESSURE REGULATOR

Pressure regulators must always be installed downstream from all shut-off valves in the proper direction.

Each model has a directional arrow on the side that shows the direction of the flow. This arrow should point downstream, toward the sprinklers and emitters.

Hydraulic friction loss is what makes a pressure regulator work. To compensate for friction inside the device, the recommendation is to assure inlet pressure is 5 psi (0.34 bar) higher than the regulator preset psi rating.

Each pressure regulator is designed with a maximum pressure rating, typically 80 psi (5.51 bar) above the designed pressure rating for that model. Operating outside these recommendations will affect the regulator's performance and could cause premature failure.

PRESET OUTLET PRESSURE	MAXIMUM INLET PRESSURE
6 psi (0.41 bar)	80 psi (5.51 bar)
10 psi (0.69 bar)	90 psi (6.20 bar)
12 psi (0.83 bar)	90 psi (6.20 bar)
15 psi (1.03 bar)	95 psi (6.55 bar)
20 psi (1.38 bar)	100 psi (6.89 bar)
25 psi (1.72 bar)	105 psi (7.24 bar)
30 psi (2.07 bar)	110 psi (7.58 bar)
35 psi (2.41 bar)	115 psi (7.93 bar)
40 psi (2.76 bar)	120 psi (8.27 bar)
50 psi (3.45 bar)	130 psi (8.96 bar)

Mechanized systems –

- Pressure regulators are usually installed immediately preceding the sprinkler.
- Some prefer to install pressure regulators directly into the outlet on the pivot span or on the outlet side of the gooseneck. Increased pressure between the regulator and the sprinkler should be a design consideration.

Solid Set field installations –

- Regulators are usually installed at the beginning of the lateral. Although, based on the design, one regulator can be used to manage pressure for several laterals.
- Certain installations may require a pressure regulator for each sprinkler.
- In high flow scenarios, a high flow model should be used. Although, multiple regulators in manifold can be used to handle the specific flow requirements.
- Timer-control installations employ regulators after the control valve, whether for multiple units or inside a valve box.



HOW LONG DO PRESSURE REGULATORS LAST?

Though regulators can last for years, the degree of regulation will change over time as internal parts begin to wear. The conditions under which pressure regulators operate influence their lifespan. Various factors contribute to pressure regulator wear, including poor water quality, unflushed chemicals in the system, abrasive materials in the water, and extended operating hours. Plan to do a yearly check or after every 2,000 hours, whichever comes first. Any significant variance will mean a loss of efficiency and revenue in the long run. At 10,000 hours, you should review the original design parameters of the system, do random checks on two or more sprinklers per span, and see if you have any variance to the original specifications.

WHAT ARE THE MAIN SIGNS OF WEAR?

Malfunctioning pressure regulators can be difficult to identify visually. However, some emit water through the sides of the regulator when they fail structurally, which often happens because the regulator was installed before a shut-off valve. Sometimes they also produce a high-pitched squealing.

A malfunctioning regulator can result in a sprinkler pressure that will be too high. A sprinkler emitting a finer spray or exhibiting a faster rotation speed relative to adjacent sprinklers may indicate a regulator is operating above its nominal rating. If operating below its nominal rating, sprinklers will produce larger droplets and slower rotation speed, as well as reduced wetted diameter.



Inlet and outlet of worn pressure regulators.

HOW TO TEST PRESSURE REGULATORS

All users should check their pressure regulators at least once every three years. You can test pressure regulators by installing a high-quality pressure gauge on each side of the regulator.

The gauge on the inlet side assures there is enough pressure for the regulator to operate. Remember that inlet pressure should be at least 5 psi (0.34 bar) above the pressure regulator rating for the regulator to function. The gauge on the outlet side (after the regulator) should match the preset pressure printed on the device, allowing for slight variation due to flow.



If your irrigation dealer has a regulating testing device, you can also check the readings on a new pressure regulator that matches the model you are testing.

SennREG™ APP

The SennREG app is a handy tool to bring into the field when checking your pressure regulator's performance. It shows the relationship pressure has on flow in either Imperial or Metric units. With just a few clicks, you'll know exactly what to expect out of your pressure regulator – from what your output pressure should be to when you should start thinking about replacements.

- Select your Senninger pressure regulator model and desired outlet pressure. Be sure you have at least 5 psi (0.34 bar) above the regulated pressure available for the regulator selected.
- Select the UP3 nozzle number currently installed in your sprinkler.
- Enter your expected flow numerically.
- Enter your overall system pressure.

Test your pressure regulator to see the outlet pressure. In the SennREG app, replace the outlet pressure with your actual pressure and review the results on the chart. If the line falls within the green area, the pressure regulator operates as intended. If it falls within the yellow area, use caution and monitor system performance. If it falls within the red area, it is time to replace your pressure regulators.

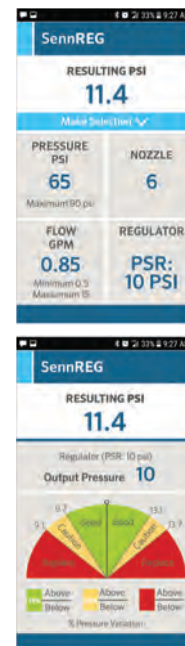

■ Download the app for **Apple or Android devices** from the app store.

PRESSURE REGULATION

DYNAMIC OR STATIC

DYNAMIC - PRESSURE REGULATOR

Dynamic pressure regulators must always be installed **downstream** from all shut-off valves and filters in the proper direction. Each model has a directional arrow on the side that shows the direction of the flow. This arrow should point downstream, toward the sprinklers and emitters.

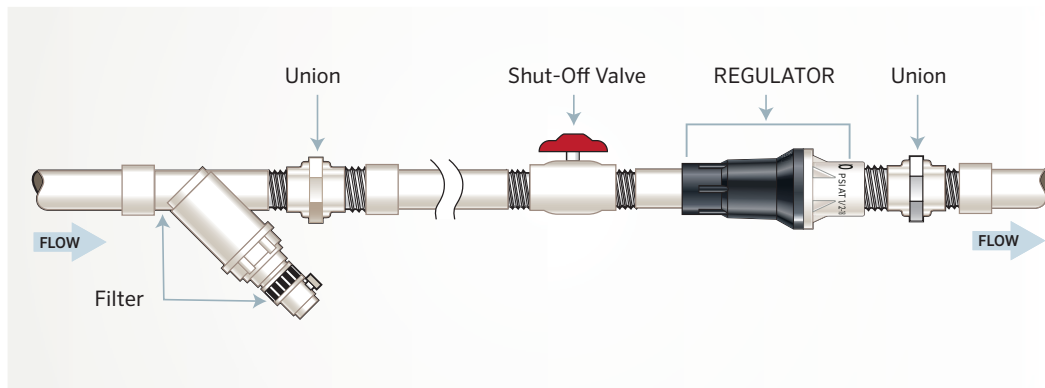

STATIC - PRESSURE REGULATING LIMIT VALVE

Static pressure regulators, like our Pressure Regulating Limit Valve (PRLV and PRXF-LV) must always be installed **upstream** from all shut-off valves and filters in the proper direction. Each model has a directional arrow on the side that shows the direction of the flow. This arrow should point downstream, toward the sprinklers and emitters.

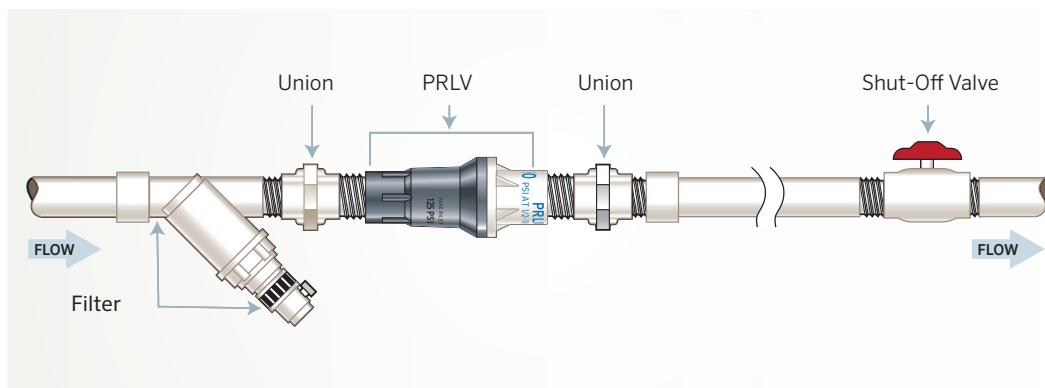

WHY SENNINGER PRESSURE REGULATORS?



Recognizing the importance of maintaining correct system pressure, Senninger introduced the first in-line pressure regulators to the industry in 1966. This revolutionized the irrigation industry by improving overall system performance and efficiency.

Senninger continued to develop the concept earning several patents on additional design features. The Senninger black and white pressure regulators are known worldwide for their accuracy and reliable performance.

The design and materials used to manufacture pressure regulators greatly impact their accuracy. Senninger pressure regulators are designed and built to rigorous quality standards. They are 100% pressure tested to ensure quality and performance before they are packaged and shipped. Senninger pressure regulators are backed with a two-year warranty on materials, workmanship, and performance.

Several models have been developed throughout the years to meet a variety of installation needs including mechanized systems, nurseries, greenhouses, and open fields.



HOW TO SELECT A PRESSURE REGULATOR

When selecting the proper pressure regulator for an irrigation system, there are several factors to consider. These include the range of fluctuations in inlet pressure, the required outlet pressure, and the allowable variation.

Other factors are:

- The maximum flow rate required and expected variation
- Any size and inlet/outlet connection constraints
- Any specific application needs such as those in wastewater or mining installations

Note that in many instances, irrigation design software such as the Senninger SennPAQ™ or WinSIPP™ programs will automatically let you know what type of pressure regulator you need.





MPR MINI PRESSURE REGULATOR



The Senninger Mini Pressure Regulator (MPR) is an economical solution to help reduce excessive pressure. Because pressure impacts flow, the MPR reduces flow fluctuations so that each sprinkler performs consistently and helps reduce overwatering throughout the irrigation zone, including changing elevations and long lateral runs.

Product Specs	
Flow	0.5 - 3.5 gpm (114 - 804 L/hr)
Pressure	15 - 40 psi (1.0 - 2.8 bar)

FEATURES

- Designed for use immediately beneath the sprinkler
- Maintains the sprinkler's designed flow to +/-10% of nominal flow
- Allows pressure regulation on sprinklers along laterals or mainlines with up to 115 ft (35 m) elevation change.
- Inlet size: 1/2" male NPT
- Outlet size: 1/2" female NPT
- Models available: 15 psi (1.0 bar), 20 psi (1.4 bar), 30 psi (2.1 bar), and 40 psi (2.8 bar)
- Senninger pressure regulators are available with models for a wide range of flows
- Two-year warranty on materials, workmanship, and performance

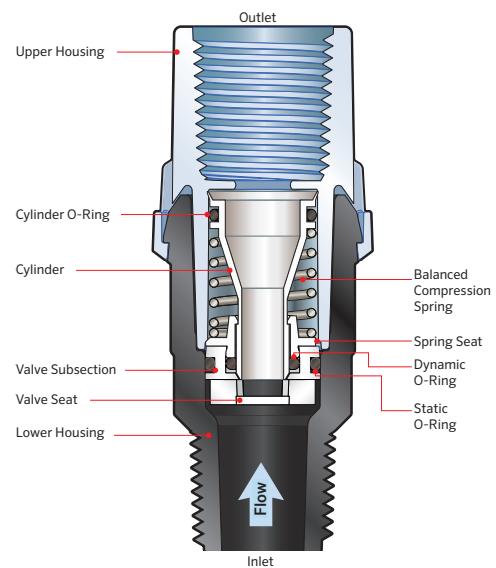



MPR MINI PRESSURE REGULATOR

Sprinkler	Nozzles	Model MPR
mini-Wobbler™	#4 - #8 nozzles	15 or 20 psi (1.0 or 1.4 bar)
Xcel-Wobbler™	#6 - #9 nozzles	20 psi (1.4 bar)
Smooth Drive™	#6 - #8 nozzles	30 or 40 psi (2.1 or 2.8 bar)
20 Series Impacts	#6 - #9 nozzles	30 or 40 psi (2.1 or 2.8 bar)

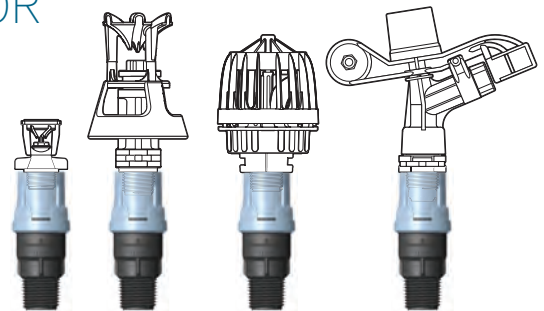

MPR MODELS	Description	Preset Outlet Pressure	Maximum Inlet Pressure	Flow Range
MPR152M2F	15 psi, inlet 1/2" M NPT, outlet 1/2" F NPT	15 psi (1.0 bar)	45 psi (3.1 bar)	0.5 - 2.3 gpm (114 - 513 L/hr)
MPR202M2F	20 psi, inlet 1/2" M NPT, outlet 1/2" F NPT	20 psi (1.4 bar)	50 psi (3.5 bar)	0.5 - 2.5 gpm (114 - 559 L/hr)
MPR302M2F	30 psi, inlet 1/2" M NPT, outlet 1/2" F NPT	30 psi (2.1 bar)	60 psi (4.1 bar)	0.6 - 3.1 gpm (136 - 704 L/hr)
MPR402M2F	40 psi, inlet 1/2" M NPT, outlet 1/2" F NPT	40 psi (2.8 bar)	80 psi (5.5 bar)	0.7 - 3.5 gpm (159 - 804 L/hr)

The pressure regulator shall maintain the predetermined pressure provided that the inlet pressure is at least 5 psi (0.3 bar) above the expected outlet pressure, but not exceeding the maximum inlet pressure as shown in this chart.

Pressure regulators should always be installed downstream of all shut-off valves.

Recommended for outdoor use only. Not NSF certified.

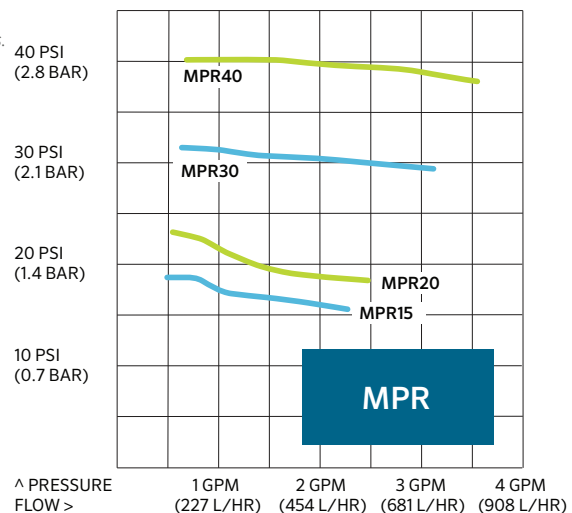



PRLG PRESSURE REGULATOR LANDSCAPE GRADE



The Senninger PRLG (Pressure Regulator Landscape Grade) is ideal for installations requiring lower flows. It is ideal for irrigation systems connected to hose bibb faucets or other lawn and landscape applications.

Product Specs	
Flow	0.5 - 7 gpm (114 - 1590 L/hr)
Pressure	10 - 40 psi (0.69 - 2.76 bar)

FEATURES

- Maintains a constant preset outlet pressure while handling varying inlet pressures
- Inlet sizes: 3/4" female NPT and 3/4" female hose
- Outlet sizes: 3/4" male NPT and 3/4" male hose
- Models available: 10 psi (0.69 bar), 15 psi (1.03 bar), 20 psi (1.38 bar), 25 psi (1.72 bar), 30 psi (2.07 bar), 35 psi (2.41 bar), and 40 psi (2.76 bar)
- Tamper-proof housing
- Very low hysteresis and friction losses
- Pressure-tested for accuracy
- No external metal parts for excellent corrosion resistance
- Two-year warranty on materials, workmanship, and performance

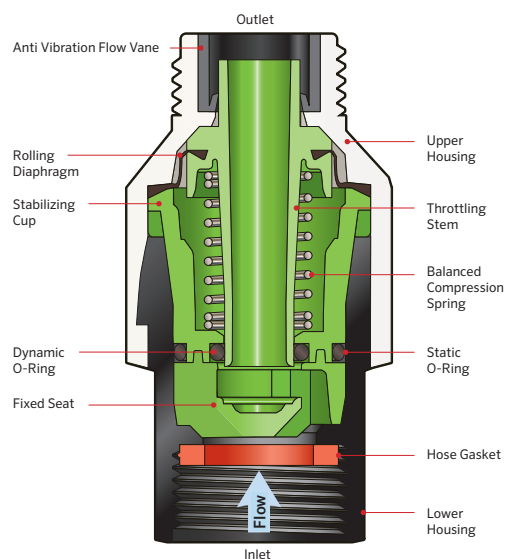

PRLG PRESSURE REGULATOR LANDSCAPE GRADE

PRLG MODELS	Description	Preset Outlet Pressure	Maximum Inlet Pressure	Flow Range
PRLG103F3M	10 psi, inlet 3/4" F NPT, outlet 3/4" M NPT	10 psi (0.69 bar)	90 psi (6.20 bar)	0.5 - 7 gpm (114 - 1590 L/hr)
PRLG153F3M	15 psi, inlet 3/4" F NPT, outlet 3/4" M NPT	15 psi (1.03 bar)	95 psi (6.55 bar)	0.5 - 7 gpm (114 - 1590 L/hr)
PRLG203F3M	20 psi, inlet 3/4" F NPT, outlet 3/4" M NPT	20 psi (1.38 bar)	100 psi (6.89 bar)	0.5 - 7 gpm (114 - 1590 L/hr)
PRLG253F3M	25 psi, inlet 3/4" F NPT, outlet 3/4" M NPT	25 psi (1.72 bar)	105 psi (7.24 bar)	0.5 - 7 gpm (114 - 1590 L/hr)
PRLG303F3M	30 psi, inlet 3/4" F NPT, outlet 3/4" M NPT	30 psi (2.07 bar)	110 psi (7.58 bar)	0.5 - 7 gpm (114 - 1590 L/hr)
PRLG353F3M	35 psi, inlet 3/4" F NPT, outlet 3/4" M NPT	35 psi (2.41 bar)	115 psi (7.93 bar)	0.5 - 7 gpm (114 - 1590 L/hr)
PRLG403F3M	40 psi, inlet 3/4" F NPT, outlet 3/4" M NPT	40 psi (2.76 bar)	120 psi (8.27 bar)	0.5 - 7 gpm (114 - 1590 L/hr)

For the 3/4" female hose x 3/4" female hose connection model, use this part number replacing xx with Preset Outlet Pressure above - PRLGxx3FH3MH

The pressure regulator shall maintain the predetermined pressure provided that the inlet pressure is at least 5 psi (0.34 bar) above the expected outlet pressure, but not exceeding the maximum inlet pressure as shown in this chart.

Pressure regulators should always be installed downstream of all shut-off valves.

Recommended for outdoor use only. Not NSF certified.

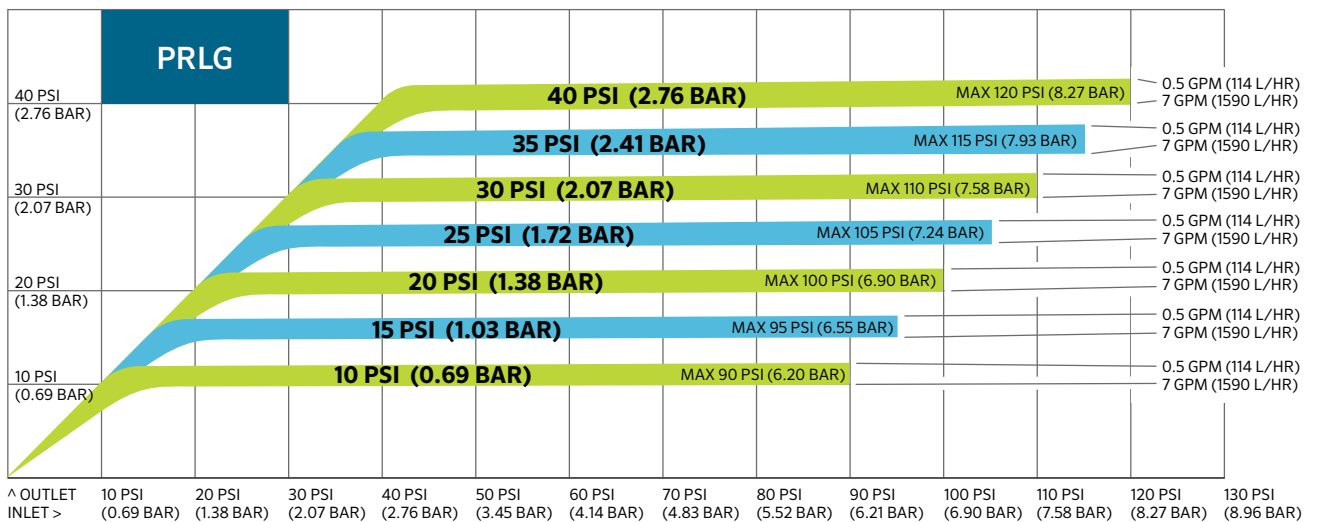

Every pressure regulator is designed to operate at a minimum and maximum inlet pressure and a predetermined flow range. This regulator performance curve illustrates how the PRLG will perform within the range of inlet pressures and flows.

The Y-axis shows outlet pressure, and the X-axis shows inlet pressure. In this chart, the band for the 30 psi (2.07 bar) model shows the performance at various flows. At the lowest flow (0.5 gpm or 114 L/hr), the regulator will maintain an actual outlet pressure slightly higher than 30 psi (2.07 bar). In contrast, at the highest flow (7 gpm or 1590 L/hr), the actual outlet pressure will be slightly lower than 30 psi (2.07 bar)*.

*Source: Rogers, Shaw, Pragada, & Alam, 2010.



PRL PRESSURE REGULATOR LOW FLOW



The Senninger PRL (Pressure Regulator Low Flow) is ideal for installations requiring lower flows. Suggested use in solid-set, drip, other low-volume irrigation systems, as well as center pivot and mechanical-move irrigation systems.

Product Specs	
Flow	0.5 - 8 gpm (114 - 1817 L/hr)
Pressure	6 - 40 psi (0.41 - 2.76 bar)

FEATURES

- Maintains a constant preset outlet pressure while handling varying inlet pressures
- Inlet sizes: 3/4" female NPT and 3/4" female hose
- Outlet sizes: 3/4" female NPT
- Models available: 6 psi (0.41 bar), 10 psi (0.69 bar), 12 psi (0.83 bar), 15 psi (1.03 bar), 20 psi (1.38 bar), 25 psi (1.72 bar), 30 psi (2.07 bar), 35 psi (2.41 bar), and 40 psi (2.76 bar)
- Tamper-proof housing
- Very low hysteresis and friction losses
- Pressure-tested for accuracy
- No external metal parts for excellent corrosion resistance
- Two-year warranty on materials, workmanship, and performance

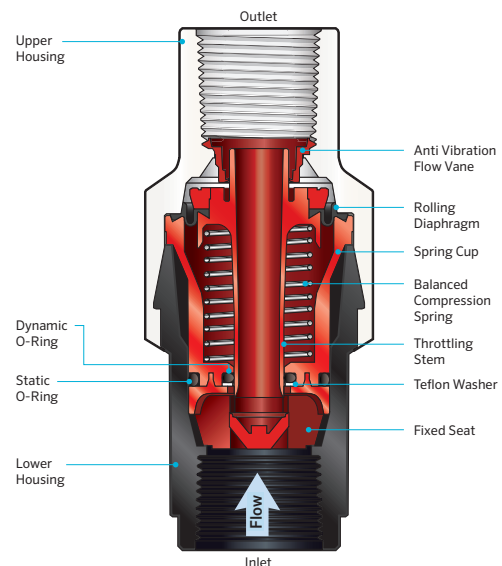

PRL PRESSURE REGULATOR LOW FLOW

PRL MODELS	Description	Preset Outlet Pressure	Maximum Inlet Pressure	Flow Range
PRL063F3F	6 psi, inlet 3/4" F NPT, outlet 3/4" F NPT	6 psi (0.41 bar)	80 psi (5.51 bar)	0.5 - 5 gpm (114 - 1136 L/hr)
PRL103F3F	10 psi, inlet 3/4" F NPT, outlet 3/4" F NPT	10 psi (0.69 bar)	90 psi (6.20 bar)	0.5 - 8 gpm (114 - 1817 L/hr)
PRL123F3F	12 psi, inlet 3/4" F NPT, outlet 3/4" F NPT	12 psi (0.83 bar)	90 psi (6.20 bar)	0.5 - 8 gpm (114 - 1817 L/hr)
PRL153F3F	15 psi, inlet 3/4" F NPT, outlet 3/4" F NPT	15 psi (1.03 bar)	95 psi (6.55 bar)	0.5 - 8 gpm (114 - 1817 L/hr)
PRL203F3F	20 psi, inlet 3/4" F NPT, outlet 3/4" F NPT	20 psi (1.38 bar)	100 psi (6.89 bar)	0.5 - 8 gpm (114 - 1817 L/hr)
PRL253F3F	25 psi, inlet 3/4" F NPT, outlet 3/4" F NPT	25 psi (1.72 bar)	105 psi (7.24 bar)	0.5 - 8 gpm (114 - 1817 L/hr)
PRL303F3F	30 psi, inlet 3/4" F NPT, outlet 3/4" F NPT	30 psi (2.07 bar)	110 psi (7.58 bar)	0.5 - 8 gpm (114 - 1817 L/hr)
PRL353F3F	35 psi, inlet 3/4" F NPT, outlet 3/4" F NPT	35 psi (2.41 bar)	115 psi (7.93 bar)	0.5 - 8 gpm (114 - 1817 L/hr)
PRL403F3F	40 psi, inlet 3/4" F NPT, outlet 3/4" F NPT	40 psi (2.76 bar)	120 psi (8.27 bar)	0.5 - 8 gpm (114 - 1817 L/hr)

For the 3/4" female hose x 3/4" male NPT connection model, use this part number replacing xx with Preset Outlet Pressure above - PRLxx3FH3M

The pressure regulator shall maintain the predetermined pressure provided that the inlet pressure is at least 5 psi (0.34 bar) above the expected outlet pressure, but not exceeding the maximum inlet pressure as shown in this chart.

Pressure regulators should always be installed downstream of all shut-off valves.

Recommended for outdoor use only. Not NSF certified.

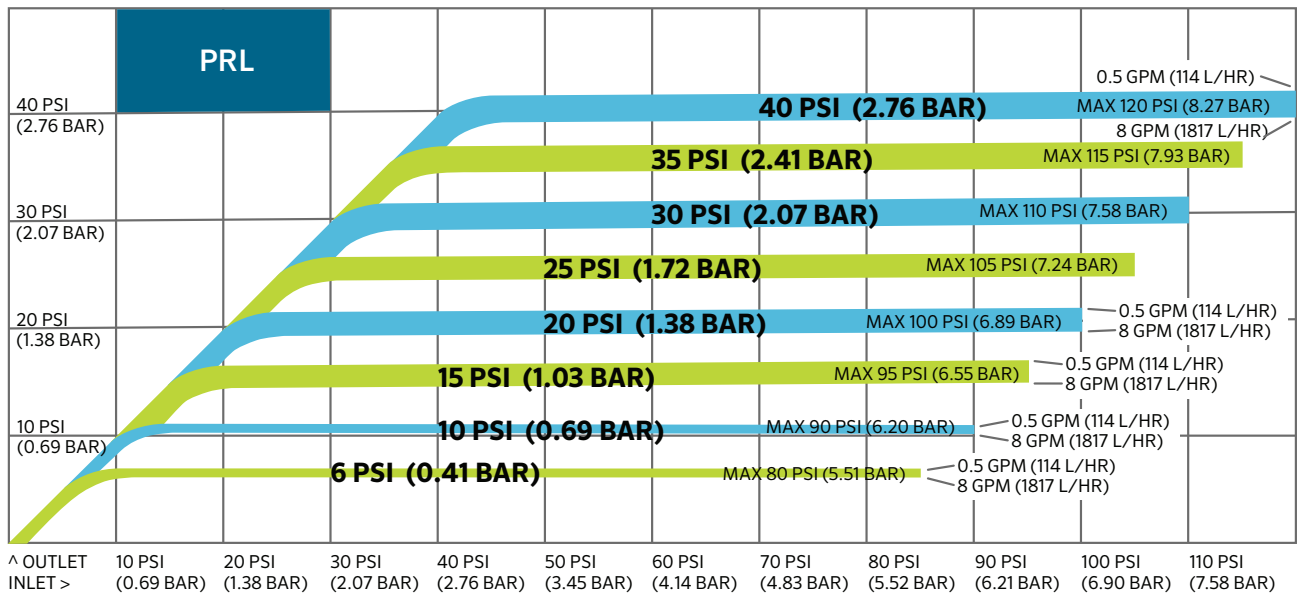

Every pressure regulator is designed to operate at a minimum and maximum inlet pressure and a predetermined flow range. This regulator performance curve illustrates how the PRL will perform within the range of inlet pressures and flows.

The Y-axis shows outlet pressure, and the X-axis shows inlet pressure. In this chart, the band for the 30 psi (2.07 bar) model shows the performance at various flows. At the lowest flow (0.5 gpm or 114 L/hr), the regulator will maintain an actual outlet pressure slightly higher than 30 psi (2.07 bar). In contrast, at the highest flow (8 gpm or 1817 L/hr), the actual outlet pressure will be slightly lower than 30 psi (2.07 bar)*.

*Source: Rogers, Shaw, Pragada, & Alam, 2010.



PSR™2 PIVOT SPECIAL REGULATOR



The Senninger PSR2 (Pivot Special Regulator) is ideal for mechanical move installations. Its wide flow range allows irrigators to use one model along the entire length of the machine. Its patented design is ideal for systems pumping surface water.

Product Specs	
Flow	0.5 - 15 gpm (114 - 3407 L/hr)
Pressure	6 - 50 psi (0.41 - 3.45 bar)

FEATURES

- Maintains a constant preset outlet pressure while handling varying inlet pressures
- Inlet size: 3/4" female NPT
- Outlet size: 3/4" female NPT
- Models available: 6 psi (0.41 bar), 10 psi (0.69 bar), 12 psi (0.83 bar), 15 psi (1.03 bar), 20 psi (1.38 bar), 25 psi (1.72 bar), 30 psi (2.07 bar), 35 psi (2.41 bar), 40 psi (2.76 bar), and 50 psi (3.45 bar)
- Tamper-proof housing
- Very low hysteresis and friction losses
- Pressure-tested for accuracy
- No external metal parts for excellent corrosion resistance
- Two-year warranty on materials, workmanship, and performance

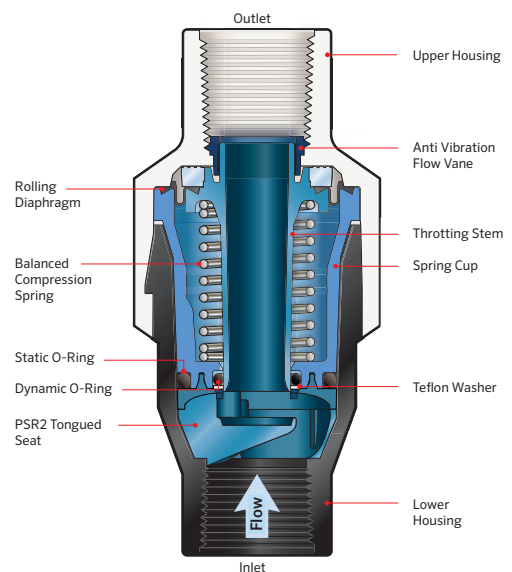

PSR™2 PIVOT SPECIAL REGULATOR

PSR2 MODELS	Description	Preset Outlet Pressure	Maximum Inlet Pressure	Flow Range
PSR2063F3F	6 psi, inlet 3/4" F NPT, outlet 3/4" F NPT	6 psi (0.41 bar)	80 psi (5.51 bar)	0.5 - 15 gpm (114 - 3407 L/hr)
PSR2103F3F	10 psi, inlet 3/4" F NPT, outlet 3/4" F NPT	10 psi (0.69 bar)	90 psi (6.20 bar)	0.5 - 15 gpm (114 - 3407 L/hr)
PSR2123F3F	12 psi, inlet 3/4" F NPT, outlet 3/4" F NPT	12 psi (0.83 bar)	90 psi (6.20 bar)	0.5 - 15 gpm (114 - 3407 L/hr)
PSR2153F3F	15 psi, inlet 3/4" F NPT, outlet 3/4" F NPT	15 psi (1.03 bar)	95 psi (6.55 bar)	0.5 - 15 gpm (114 - 3407 L/hr)
PSR2203F3F	20 psi, inlet 3/4" F NPT, outlet 3/4" F NPT	20 psi (1.38 bar)	100 psi (6.89 bar)	0.5 - 15 gpm (114 - 3407 L/hr)
PSR2253F3F	25 psi, inlet 3/4" F NPT, outlet 3/4" F NPT	25 psi (1.72 bar)	105 psi (7.24 bar)	0.5 - 15 gpm (114 - 3407 L/hr)
PSR2303F3F	30 psi, inlet 3/4" F NPT, outlet 3/4" F NPT	30 psi (2.07 bar)	110 psi (7.58 bar)	0.5 - 15 gpm (114 - 3407 L/hr)
PSR2353F3F	35 psi, inlet 3/4" F NPT, outlet 3/4" F NPT	35 psi (2.41 bar)	115 psi (7.93 bar)	0.5 - 15 gpm (114 - 3407 L/hr)
PSR2403F3F	40 psi, inlet 3/4" F NPT, outlet 3/4" F NPT	40 psi (2.76 bar)	120 psi (8.27 bar)	0.5 - 15 gpm (114 - 3407 L/hr)
PSR2503F3F	50 psi, inlet 3/4" F NPT, outlet 3/4" F NPT	50 psi (3.45 bar)	130 psi (8.96 bar)	0.5 - 15 gpm (114 - 3407 L/hr)

The pressure regulator shall maintain the predetermined pressure provided that the inlet pressure is at least 5 psi (0.34 bar) above the expected outlet pressure, but not exceeding the maximum inlet pressure as shown in this chart.

Pressure regulators should always be installed downstream of all shut-off valves.

Recommended for outdoor use only. Not NSF certified.

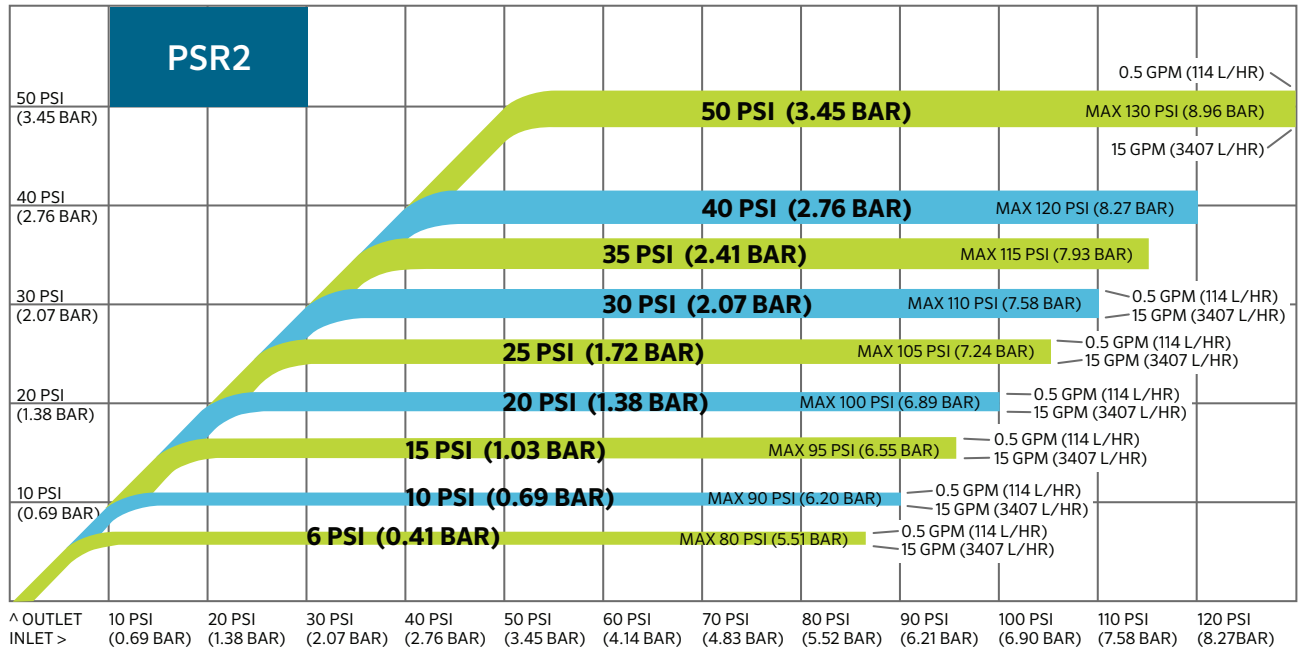

Every pressure regulator is designed to operate at a minimum and maximum inlet pressure and a predetermined flow range. This regulator performance curve illustrates how the PSR2 will perform within the range of inlet pressures and flows.

The Y-axis shows outlet pressure, and the X-axis shows inlet pressure. In this chart, the band for the 30 psi (2.07 bar) model shows the performance at various flows. At the lowest flow (0.5 gpm or 114 L/hr), the regulator will maintain an actual outlet pressure slightly higher than 30 psi (2.07 bar). In contrast, at the highest flow (15 gpm or 3407 L/hr), the actual outlet pressure will be slightly lower than 30 psi (2.07 bar)*.

*Source: Rogers, Shaw, Pragada, & Alam, 2010.



FILTER REGULATOR



The Senninger Filter Regulator combines filtration and pressure regulation into one device for installation convenience. Combining PSR2 performance with reduced nozzle clogging provides a solution for overall efficiency of an irrigation system.

Product Specs	
Flow	0.5 - 15 gpm (114 - 3407 L/hr)
Pressure	6 - 20 psi (0.41 - 1.38 bar)

FEATURES

- Maintains a constant preset outlet pressure while handling varying inlet pressures
- Quality field proven PSR2 internal components
- Easy access to mesh screens with a twist of the bonnet; no tools required; no need to dismantle the drop assembly
- Convenient installation above the sprinkler
- Inlet size: 3/4" male NPT
- Outlet size: 3/4" female NPT
- Models available: 6 psi (0.41 bar), 10 psi (0.69 bar), 15 psi (1.03 bar), and 20 psi (1.38 bar)
- Pressure-tested for accuracy
- Two-year warranty on materials, workmanship, and performance

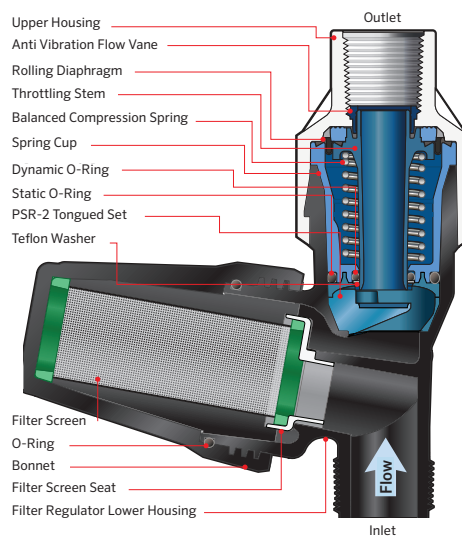

Screen Models	Description	Screen Mesh Orifice (microns)
FPSR220SCREEN	Filter PSR2, 20 mesh screen, black rings	841
FPSR230SCREEN	Filter PSR2, 30 mesh screen, green rings	595
FPSR240SCREEN	Filter PSR2, 40 mesh screen, grey rings	400
FPSR2120SCREEN	Filter PSR2, 120 mesh screen, red rings	125
FPSR2140SCREEN	Filter PSR2, 140 mesh screen, blue rings	105



Shaded models designed for use with drip systems.

Color-coded stickers available for the outer bonnet to assist installers in matching the mesh size to the correct nozzle.

Easy in-field maintenance to exchange installed filter screens for new or cleaned screens. Clean screens for reinstallation during the next scheduled maintenance cycle.

FILTER REGULATOR

FILTER REGULATOR MODELS	Description	Mesh Orifice (microns)	UP3 Nozzle Numbers	Preset Outlet Pressure	Maximum Inlet Pressure
FPSR2063M3F20	6 psi, Filter PSR2, 3/4" M NPT x 3/4" F NPT, 20 mesh screen	841	#13 - #26	6 psi (0.41 bar)	80 psi (5.51 bar)
FPSR2063M3F30	6 psi, Filter PSR2, 3/4" M NPT x 3/4" F NPT, 30 mesh screen	595	#6 - #12.5		
FPSR2063M3F40	6 psi, Filter PSR2, 3/4" M NPT x 3/4" F NPT, 40 mesh screen	400	#2 - #5.5		
FPSR2103M3F20	10 psi, Filter PSR2, 3/4" M NPT x 3/4" F NPT, 20 mesh screen	841	#13 - #26	10 psi (0.69 bar)	90 psi (6.20 bar)
FPSR2103M3F30	10 psi, Filter PSR2, 3/4" M NPT x 3/4" F NPT, 30 mesh screen	595	#6 - #12.5		
FPSR2103M3F40	10 psi, Filter PSR2, 3/4" M NPT x 3/4" F NPT, 40 mesh screen	400	#2 - #5.5		
FPSR2153M3F20	15 psi, Filter PSR2, 3/4" M NPT x 3/4" F NPT, 20 mesh screen	841	#13 - #26	15 psi (1.03 bar)	95 psi (6.55 bar)
FPSR2153M3F30	15 psi, Filter PSR2, 3/4" M NPT x 3/4" F NPT, 30 mesh screen	595	#6 - #12.5		
FPSR2153M3F40	15 psi, Filter PSR2, 3/4" M NPT x 3/4" F NPT, 40 mesh screen	400	#2 - #5.5		
FPSR2203M3F20	20 psi, Filter PSR2, 3/4" M NPT x 3/4" F NPT, 20 mesh screen	841	#13 - #26	20 psi (1.38 bar)	100 psi (6.89 bar)
FPSR2203M3F30	20 psi, Filter PSR2, 3/4" M NPT x 3/4" F NPT, 30 mesh screen	595	#6 - #12.5		
FPSR2203M3F40	20 psi, Filter PSR2, 3/4" M NPT x 3/4" F NPT, 40 mesh screen	400	#2 - #5.5		

FPSR2103M3F120	10 psi, Filter PSR2, 3/4" M NPT x 3/4" F NPT, 120 mesh screen	125	0.5 - 15 gpm (114 - 3407 L/hr)	10 psi (0.69 bar)	90 psi (6.20 bar)
FPSR2103M3F140	10 psi, Filter PSR2, 3/4" M NPT x 3/4" F NPT, 140 mesh screen	105			
FPSR2153M3F120	15 psi, Filter PSR2, 3/4" M NPT x 3/4" F NPT, 120 mesh screen	125	0.5 - 15 gpm (114 - 3407 L/hr)	15 psi (1.03 bar)	95 psi (6.55 bar)
FPSR2153M3F140	15 psi, Filter PSR2, 3/4" M NPT x 3/4" F NPT, 140 mesh screen	105			
FPSR2203M3F120	20 psi, Filter PSR2, 3/4" M NPT x 3/4" F NPT, 120 mesh screen	125	0.5 - 15 gpm (114 - 3407 L/hr)	20 psi (1.38 bar)	100 psi (6.89 bar)
FPSR2203M3F140	20 psi, Filter PSR2, 3/4" M NPT x 3/4" F NPT, 140 mesh screen	105			

Shaded models designed for use with drip systems.

The pressure regulator shall maintain the predetermined operating pressure provided that the inlet pressure is at least 5 psi (0.34 bar) above the expected outlet pressure, with flows up to 11 gpm (2498 L/hr), but not exceeding the maximum inlet pressure as shown above. Higher flows require additional inlet pressure to engage the regulator. Where flows are greater than 11 gpm (2498 L/hr), the inlet pressure should be at least 9 psi (0.62 bar) above the expected outlet pressure but not exceeding the maximum inlet pressure as shown above.

Pressure regulators should always be installed downstream of all shut-off valves.

Recommended for outdoor use only. Not NSF certified.



PMR-MF PRESSURE-MASTER REGULATOR® MEDIUM FLOW



The Senninger PMR-MF (Pressure-Master Regulator Medium Flow) is ideal for installations requiring mid-range flows. It can be installed above or below ground and is used in solid set, drip and low volume systems as well as on center pivots.

Product Specs	
Flow	2 - 20 gpm (454 - 4542 L/hr)
Pressure	6 - 60 psi (0.41 - 4.14 bar)

FEATURES

- Maintains a constant preset outlet pressure while handling varying inlet pressures
- Inlet sizes: 3/4" female NPT, 1" female NPT, and 1" female BSPT
- Outlet size: 3/4" female NPT, 1" female NPT, and 1" female BSPT
- Models available: 6 psi (0.41 bar), 10 psi (0.69 bar), 12 psi (0.83 bar), 15 psi (1.03 bar), 20 psi (1.38 bar), 25 psi (1.72 bar), 30 psi (2.07 bar), 35 psi (2.41 bar), 40 psi (2.76 bar), 50 psi (3.45 bar), and 60 psi (4.14 bar)
- Very low hysteresis and friction losses
- Pressure-tested for accuracy
- Two-year warranty on materials, workmanship, and performance.

WARNING:

DO NOT DISASSEMBLE the Pressure-Master Regulator Medium Flow. Each PMR-MF contains a compressed spring which could cause personal injury if released. Please have the dealer return PMR-MF regulators to factory for repair.

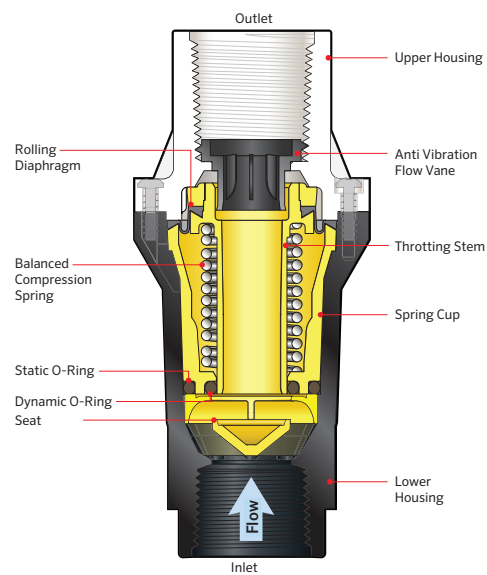

PMR-MF PRESSURE-MASTER REGULATOR® MEDIUM FLOW

PMR-MF MODELS	Description	Preset Outlet Pressure	Maximum Inlet Pressure	Flow Range
PMR06MF3F3FV	6 psi, inlet 3/4" F NPT, outlet 3/4" F NPT w/ vane	6 psi (0.41 bar)	80 psi (5.51 bar)	4 - 16 gpm (909 - 3634 L/hr)
PMR10MF3F3FV	10 psi, inlet 3/4" F NPT, outlet 3/4" F NPT w/ vane	10 psi (0.69 bar)	90 psi (6.20 bar)	4 - 16 gpm (909 - 3634 L/hr)
PMR12MF3F3FV	12 psi, inlet 3/4" F NPT, outlet 3/4" F NPT w/ vane	12 psi (0.83 bar)	90 psi (6.20 bar)	2 - 20 gpm (454 - 4542 L/hr)
PMR15MF3F3FV	15 psi, inlet 3/4" F NPT, outlet 3/4" F NPT w/ vane	15 psi (1.03 bar)	95 psi (6.55 bar)	2 - 20 gpm (454 - 4542 L/hr)
PMR20MF3F3FV	20 psi, inlet 3/4" F NPT, outlet 3/4" F NPT w/ vane	20 psi (1.38 bar)	100 psi (6.89 bar)	2 - 20 gpm (454 - 4542 L/hr)
PMR25MF3F3FV	25 psi, inlet 3/4" F NPT, outlet 3/4" F NPT w/ vane	25 psi (1.72 bar)	105 psi (7.24 bar)	2 - 20 gpm (454 - 4542 L/hr)
PMR30MF3F3FV	30 psi, inlet 3/4" F NPT, outlet 3/4" F NPT w/ vane	30 psi (2.07 bar)	110 psi (7.58 bar)	2 - 20 gpm (454 - 4542 L/hr)
PMR35MF3F3FV	35 psi, inlet 3/4" F NPT, outlet 3/4" F NPT w/ vane	35 psi (2.41 bar)	115 psi (7.93 bar)	2 - 20 gpm (454 - 4542 L/hr)
PMR40MF3F3FV	40 psi, inlet 3/4" F NPT, outlet 3/4" F NPT w/ vane	40 psi (2.76 bar)	120 psi (8.27 bar)	2 - 20 gpm (454 - 4543 L/hr)
PMR50MF3F3FV	50 psi, inlet 3/4" F NPT, outlet 3/4" F NPT w/ vane	50 psi (3.45 bar)	130 psi (8.96 bar)	2 - 20 gpm (454 - 4542 L/hr)
PMR60MF3F3FV	60 psi, inlet 3/4" F NPT, outlet 3/4" F NPT w/ vane	60 psi (4.14 bar)	140 psi (9.65 bar)	2 - 20 gpm (454 - 4542 L/hr)

For 1" female NPT x 1" female NPT connection model, use this part number replacing xx with Preset Outlet Pressure above - **PMRxxMF4F4FV**

For 1" female BSPT x 1" female BSPT connection model, use this part number replacing xx with Preset Outlet Pressure above - **PMRxxMF4FB4FBV**

The pressure regulator shall maintain the predetermined pressure provided that the inlet pressure is at least 5 psi (0.34 bar) above the expected outlet pressure, but not exceeding the maximum inlet pressure as shown in this chart.

Pressure regulators should always be installed downstream of all shut-off valves.

Recommended for outdoor use only. Not NSF certified.

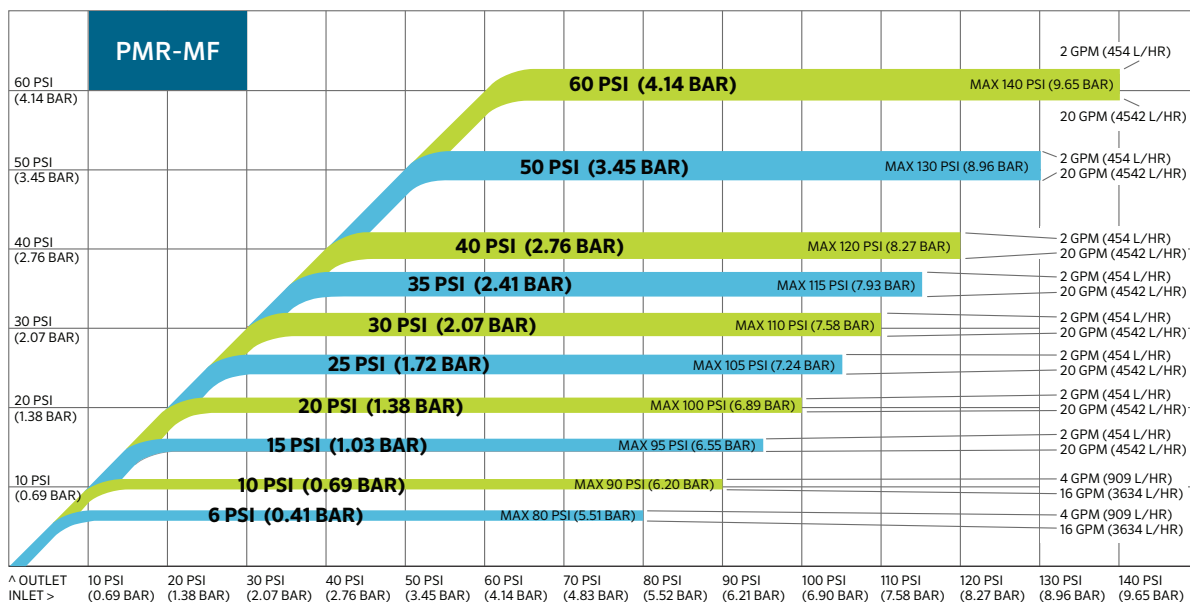

Every pressure regulator is designed to operate at a minimum and maximum inlet pressure and a predetermined flow range. This regulator performance curve illustrates how the PMR-MF will perform within the range of inlet pressures and flows.

The Y-axis shows outlet pressure, and the X-axis shows inlet pressure. In this chart, the band for the 30 psi (2.07 bar) model shows the performance at various flows. At the lowest flow (4 gpm or 909 L/hr), the regulator will maintain an actual outlet pressure slightly higher than 30 psi (2.07 bar). In contrast, at the highest flow (16 gpm or 3634 L/hr), the actual outlet pressure will be slightly lower than 30 psi (2.07 bar)*.

*Source: Rogers, Shaw, Pragada, & Alam, 2010.



PR-HF PRESSURE REGULATOR HIGH FLOW



The Senninger PR-HF (Pressure Regulator High Flow) is ideal for installations requiring higher flows. It can be installed above or below ground and is used in solid set, drip and low volume systems.

Product Specs	
Flow	10 - 32 gpm (2271 - 7268 L/hr)
Pressure	10 - 50 psi (0.69 - 3.45 bar)

FEATURES

- Maintains a constant preset outlet pressure while handling varying inlet pressures
- Inlet sizes: 1" female NPT, 1" female BSPT, 1 1/4" female NPT, 1 1/4" female BSPT
- Outlet sizes: 1" female NPT, 1 1/4" female NPT, 1 1/4" female BSPT
- Models available: 10 psi (0.69 bar), 15 psi (1.03 bar), 20 psi (1.38 bar), 25 psi (1.72 bar), 30 psi (2.07 bar), 40 psi (2.76 bar), and 50 psi (3.45 bar)
- Very low hysteresis and friction losses
- Pressure-tested for accuracy
- Two-year warranty on materials, workmanship, and performance

WARNING:

DO NOT DISASSEMBLE the Pressure Regulator High Flow. Each PR-HF contains a compressed spring which could cause personal injury if released. Please have the dealer return PR-HF regulators to factory for repair.

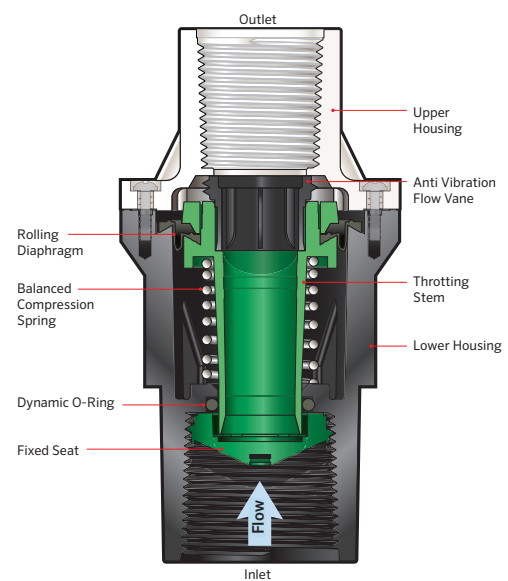

PR-HF PRESSURE REGULATOR HIGH FLOW

PR-HF MODELS	Description	Preset Outlet Pressure	Maximum Inlet Pressure	Flow Range
PR10HF5F4FV	10 psi, inlet 1 1/4" F NPT, outlet 1" F NPT	10 psi (0.69 bar)	90 psi (6.20 bar)	10 - 32 gpm (2271 - 7268 L/hr)
PR15HF5F4FV	15 psi, inlet 1 1/4" F NPT, outlet 1" F NPT	15 psi (1.03 bar)	95 psi (6.55 bar)	10 - 32 gpm (2271 - 7268 L/hr)
PR20HF5F4FV	20 psi, inlet 1 1/4" F NPT, outlet 1" F NPT	20 psi (1.38 bar)	100 psi (6.89 bar)	10 - 32 gpm (2271 - 7268 L/hr)
PR25HF5F4FV	25 psi, inlet 1 1/4" F NPT, outlet 1" F NPT	25 psi (1.72 bar)	105 psi (7.24 bar)	10 - 32 gpm (2271 - 7268 L/hr)
PR30HF5F4FV	30 psi, inlet 1 1/4" F NPT, outlet 1" F NPT	30 psi (2.07 bar)	110 psi (7.58 bar)	10 - 32 gpm (2271 - 7268 L/hr)
PR40HF5F4FV	40 psi, inlet 1 1/4" F NPT, outlet 1" F NPT	40 psi (2.76 bar)	120 psi (8.27 bar)	10 - 32 gpm (2271 - 7268 L/hr)
PR50HF5F4FV	50 psi, inlet 1 1/4" F NPT, outlet 1" F NPT	50 psi (3.45 bar)	130 psi (8.96 bar)	10 - 32 gpm (2271 - 7268 L/hr)

For 1 1/4" F NPT x 1 1/4" F NPT connection model, use this part number replacing xx with Preset Outlet Pressure above - **PRxxHF5F5FV**
 For 1 1/4" F BSPT x 1" F BSPT connection model, use this part number replacing xx with Preset Outlet Pressure above - **PRxxHF5FB4FBV**
 For 1 1/4" F BSPT x 1 1/4" F BSPT connection model, use this part number replacing xx with Preset Outlet Pressure above - **PRxxHF5FB5FBV**

The pressure regulator shall maintain the predetermined pressure provided that the inlet pressure is at least 5 psi (0.34 bar) above the expected outlet pressure, but not exceeding the maximum inlet pressure as shown in this chart.

Pressure regulators should always be installed downstream of all shut-off valves.

Recommended for outdoor use only. Not NSF certified.

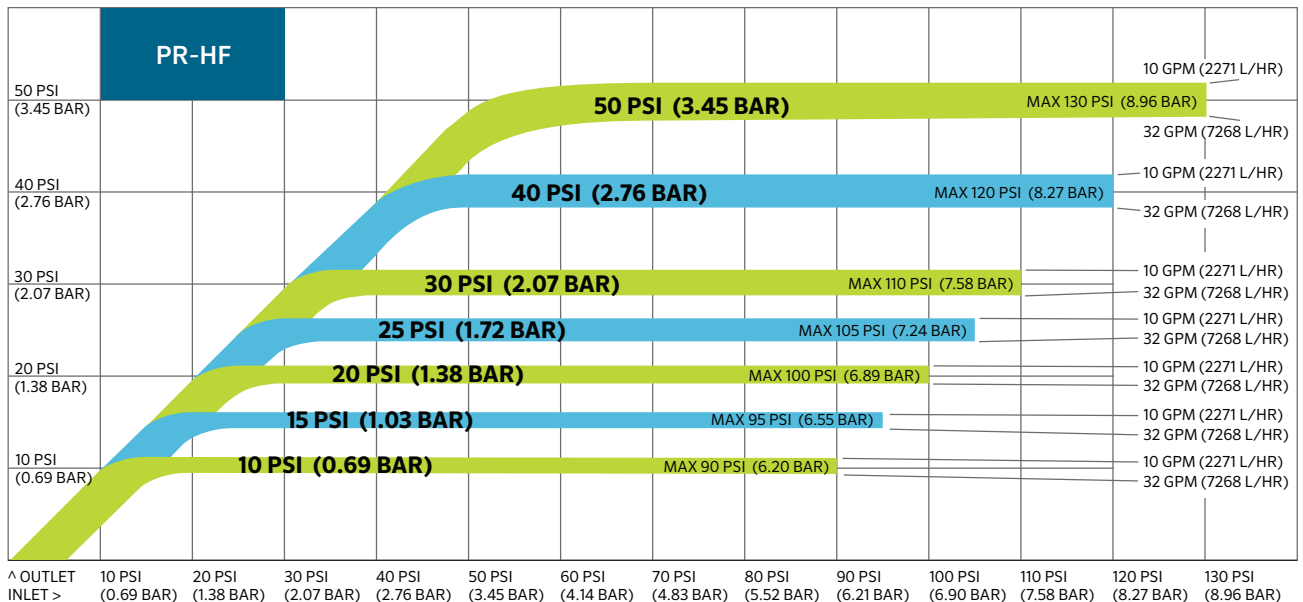

Every pressure regulator is designed to operate at a minimum and maximum inlet pressure and a predetermined flow range. This regulator performance curve illustrates how the PR-HF will perform within the range of inlet pressures and flows.

The Y-axis shows outlet pressure, and the X-axis shows inlet pressure. In this chart, the band for the 30 psi (2.07 bar) model shows the performance at various flows. At the lowest flow (10 gpm or 2271 L/hr), the regulator will maintain an actual outlet pressure slightly higher than 30 psi (2.07 bar). In contrast, at the highest flow (32 gpm or 7268 L/hr), the actual outlet pressure will be slightly lower than 30 psi (2.07 bar)*.

*Source: Rogers, Shaw, Pragada, & Alam, 2010.



PRU PRESSURE REGULATOR ULTRA



The Senninger PRU (Pressure Regulator Ultra) was designed to handle higher flows. Its 2-inch inlet and outlet size make it an ideal option for accurate zone and individual sprinkler pressure control. Its compact size fits in a valve box.

Product Specs

Flow	20 - 100 gpm (4542 - 22713 L/hr)
Pressure	10 - 60 psi (0.69 - 4.14 bar)

FEATURES

- Maintains a constant preset outlet pressure while handling varying inlet pressures
- Inlet sizes: 2" female NPT and 2" female BSPT
- Outlet size: 2" female NPT and 2" female BSPT
- Models available: 10 psi (0.69 bar), 15 psi (1.03 bar), 20 psi (1.38 bar), 25 psi (1.72 bar), 30 psi (2.07 bar), 40 psi (2.76 bar), and 50 psi (3.45 bar)
- Very low hysteresis and friction losses
- Pressure-tested for accuracy
- Two-year warranty on materials, workmanship, and performance

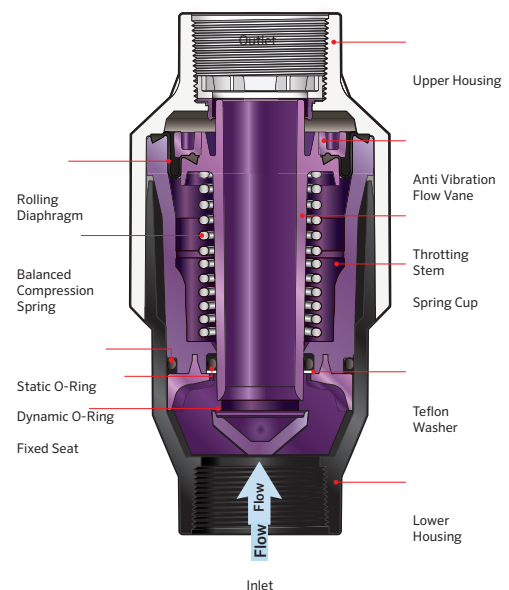

PRU PRESSURE REGULATOR ULTRA

PRU MODELS	Description	Preset Outlet Pressure	Maximum Inlet Pressure	Flow Range
PRU108F8F	10 psi, inlet 2" F NPT, outlet 2" F NPT	10 psi (0.69 bar)	90 psi (6.20 bar)	20 - 100 gpm (4542 - 22713 L/hr)
PRU158F8F	15 psi, inlet 2" F NPT, outlet 2" F NPT	15 psi (1.03 bar)	95 psi (6.55 bar)	20 - 100 gpm (4542 - 22713 L/hr)
PRU208F8F	20 psi, inlet 2" F NPT, outlet 2" F NPT	20 psi (1.38 bar)	100 psi (6.89 bar)	20 - 100 gpm (4542 - 22713 L/hr)
PRU258F8F	25 psi, inlet 2" F NPT, outlet 2" F NPT	25 psi (1.72 bar)	105 psi (7.24 bar)	20 - 100 gpm (4542 - 22713 L/hr)
PRU308F8F	30 psi, inlet 2" F NPT, outlet 2" F NPT	30 psi (2.07 bar)	110 psi (7.58 bar)	20 - 100 gpm (4542 - 22713 L/hr)
PRU408F8F	40 psi, inlet 2" F NPT, outlet 2" F NPT	40 psi (2.76 bar)	120 psi (8.27 bar)	20 - 100 gpm (4542 - 22713 L/hr)
PRU508F8F	50 psi, inlet 2" F NPT, outlet 2" F NPT	50 psi (3.45 bar)	130 psi (8.96 bar)	20 - 100 gpm (4542 - 22713 L/hr)
PRU608F8F	60 psi, inlet 2" F NPT, outlet 2" F NPT	60 psi (4.14 bar)	140 psi (9.65 bar)	20 - 100 gpm (4542 - 22713 L/hr)

For 2" F BSPT x 2" F BSPT connection model, use this part number replacing xx with Preset Outlet Pressure above - PRUxx8FB8FBV

The pressure regulator shall maintain the predetermined pressure provided that the inlet pressure is at least 5 psi (0.34 bar) above the expected outlet pressure, but not exceeding the maximum inlet pressure as shown in this chart.

Pressure regulators should always be installed downstream of all shut-off valves.

Recommended for outdoor use only. Not NSF certified.

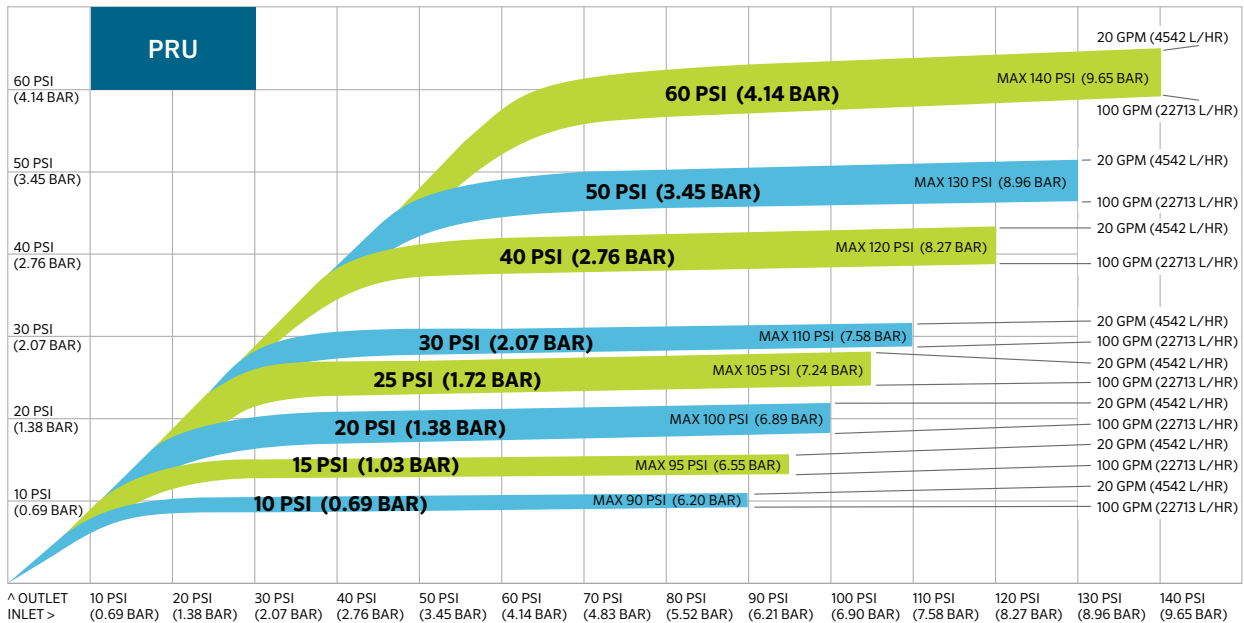

Every pressure regulator is designed to operate at a minimum and maximum inlet pressure and a predetermined flow range. This regulator performance curve illustrates how the PRU will perform within the range of inlet pressures and flows.

The Y-axis shows outlet pressure, and the X-axis shows inlet pressure. In this chart, the band for the 30 psi (2.07 bar) model shows the performance at various flows. At the lowest flow (20 gpm or 4542 L/hr), the regulator will maintain an actual outlet pressure slightly higher than 30 psi (2.07 bar). In contrast, at the highest flow (100 gpm or 22713 L/hr), the actual outlet pressure will be slightly lower than 30 psi (2.07 bar)*.

*Source: Rogers, Shaw, Pragada, & Alam, 2010.



PRLV PRESSURE REGULATING LIMIT VALVE



The Senninger PRLV (Pressure Regulating Limit Valve) is designed to be used in place of a standard water pressure regulator to limit static (no flow) water pressure when a shut-off valve is used downstream from the regulation point.

Product Specs	
Flow	up to 18 gpm (up to 4088 L/hr)
Pressure	10 - 60 psi (0.69 - 4.14 bar)

FEATURES

- Limits downstream pressure to no more than 15 psi (1.03 bar) above regulated pressure rating during static (no flow) conditions
- Inlet sizes: 3/4" female NPT and 1" female NPT
- Outlet size: 3/4" female NPT and 1" female NPT
- Models available: 10 psi (0.69 bar), 15 psi (1.03 bar), 20 psi (1.38 bar), 30 psi (2.07 bar), 40 psi (2.76 bar), and 50 psi (3.45 bar)
- Very low hysteresis and friction losses
- Pressure-tested for accuracy
- One-year warranty on materials, workmanship, and performance

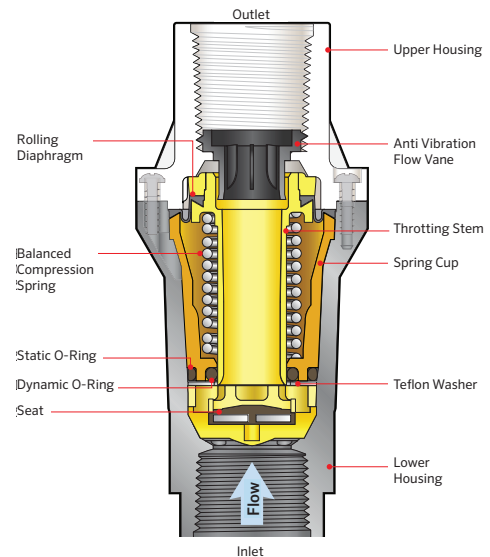

DESIGN NOTES

Because the Pressure Regulating Limit Valve is designed to operate with clean water, the use of a filter upstream of all PRLV's is recommended. Filters should be 100 mesh or finer and be capable of flowing up to 15 gpm (3407 L/hr) with no more than 5 psi (0.34 bar) internal friction loss.

If all shutoff valves are upstream from the point of regulation, then the use of a Senninger Pressure Regulator is recommended instead of a PRLV.

WARNING:

DO NOT DISASSEMBLE the Pressure Regulating Limit Valve. Each PRLV contains a compressed spring which could cause personal injury if released. Please have the dealer return PRLV valves to factory for repair.

PRLV PRESSURE REGULATING LIMIT VALVE

PRLV MODELS	Description	Preset Outlet Pressure	Maximum Inlet Pressure	Flow Range
PRLV10MF3F3FV	10 psi, inlet 3/4" F NPT, outlet 3/4" F NPT	10 psi (0.69 bar)	125 psi (8.62 bar)	up to 18 gpm (up to 4088 L/hr)
PRLV15MF3F3FV	15 psi, inlet 3/4" F NPT, outlet 3/4" F NPT	15 psi (1.03 bar)	125 psi (8.62 bar)	up to 18 gpm (up to 4088 L/hr)
PRLV20MF3F3FV	20 psi, inlet 3/4" F NPT, outlet 3/4" F NPT	20 psi (1.38 bar)	125 psi (8.62 bar)	up to 18 gpm (up to 4088 L/hr)
PRLV30MF3F3FV	30 psi, inlet 3/4" F NPT, outlet 3/4" F NPT	30 psi (2.07 bar)	125 psi (8.62 bar)	up to 18 gpm (up to 4088 L/hr)
PRLV40MF3F3FV	40 psi, inlet 3/4" F NPT, outlet 3/4" F NPT	40 psi (2.76 bar)	125 psi (8.62 bar)	up to 18 gpm (up to 4088 L/hr)
PRLV50MF3F3FV	50 psi, inlet 3/4" F NPT, outlet 3/4" F NPT	50 psi (3.45 bar)	125 psi (8.62 bar)	up to 18 gpm (up to 4088 L/hr)
PRLV60MF3F3FV	60 psi, inlet 3/4" F NPT, outlet 3/4" F NPT	60 psi (4.14 bar)	125 psi (8.62 bar)	up to 18 gpm (up to 4088 L/hr)

Для модели с соединением 1" с внутренней резьбой NPT x 1" с внутренней резьбой NPT используйте этот номер детали, заменяя xx на указанное выше заданное выходное давление - PRLVxxMF4F4FV

The PRLV limits downstream pressure to no more than 15 psi (1.03 bar) above regulated pressure during static (no flow) conditions.

Recommended for outdoor use only. Not NSF certified.

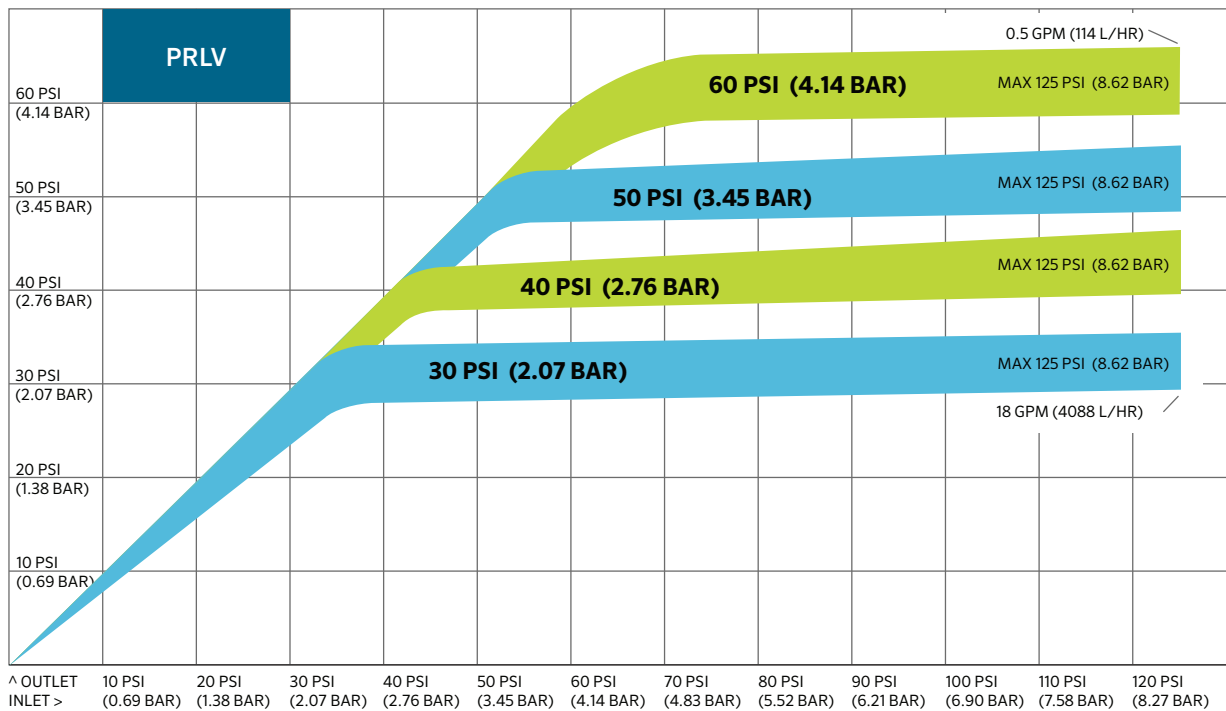

Every pressure regulating limit valve is designed to operate at a minimum and maximum inlet pressure and a predetermined flow range. This performance curve illustrates how the PRLV will perform within the range of inlet pressures and flows.

The Y-axis shows outlet pressure, and the X-axis shows inlet pressure. In this chart, the band for the 30 psi (2.07 bar) model shows the performance at various flows. At the lowest flow (0.5 gpm or 114 L/hr), the regulator will maintain an actual outlet pressure slightly higher than 30 psi (2.07 bar). In contrast, at the highest flow (18 gpm or 4088 L/hr), the actual outlet pressure will be slightly lower than 30 psi (2.07 bar)*.

*Source: Rogers, Shaw, Pragada, & Alam, 2010.



PRXF-LV PRESSURE REGULATING EXTENDED FLOW LIMIT VALVE



The Senninger PRXF-LV (Pressure Regulating Extended Flow Limit Valve) is designed to be used in place of a standard water pressure regulator to limit static (no flow) water pressure when a shut-off valve is used downstream from the regulation point.

Product Specs	
Flow	up to 75 gpm (up to 17034 L/hr)
Pressure	20 - 60 psi (1.38 - 4.14 bar)

FEATURES

- Limits downstream pressure to no more than 15 psi (1.03 bar) above regulated pressure rating during static (no flow) conditions
- Inlet size: 3" female slip
- Outlet size: 3" female slip
- Models available: 20 psi (1.38 bar), 30 psi (2.07 bar), 40 psi (2.76 bar), 50 psi (3.45 bar), and 60 psi (4.14 bar)
- Very low hysteresis and friction losses
- Pressure-tested for accuracy
- One-year warranty on materials, workmanship, and performance

WARNING:

DO NOT DISASSEMBLE the Pressure Regulating Extended Flow Limit Valve nor the internal PRLV units. Each internal PRLV contains a compressed spring which could cause personal injury if released. Please have the dealer return PRXF-LV valves to factory for repair.

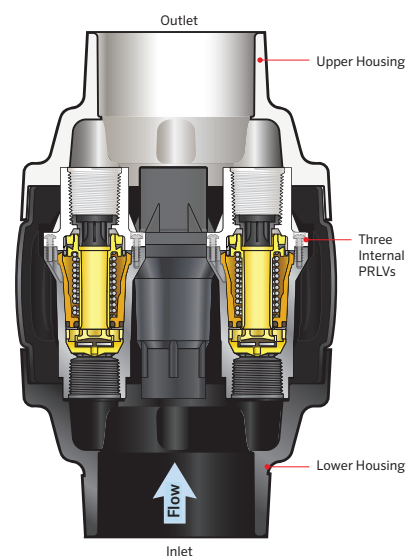

PRXF-LV PRESSURE REGULATING EXTENDED FLOW LIMIT VALVE

PRXF-LV MODELS	Description	Preset Outlet Pressure	Maximum Inlet Pressure	Flow Range
PRXF20LV3FS3FS	20 psi, inlet 3" F slip, outlet 3" F slip	20 psi (1.38 bar)	125 psi (8.62 bar)	up to 75 gpm (up to 17034 L/hr)
PRXF30LV3FS3FS	30 psi, inlet 3" F slip, outlet 3" F slip	30 psi (2.07 bar)	125 psi (8.62 bar)	up to 75 gpm (up to 17034 L/hr)
PRXF40LV3FS3FS	40 psi, inlet 3" F slip, outlet 3" F slip	40 psi (2.76 bar)	125 psi (8.62 bar)	up to 75 gpm (up to 17034 L/hr)
PRXF50LV3FS3FS	50 psi, inlet 3" F slip, outlet 3" F slip	50 psi (3.45 bar)	125 psi (8.62 bar)	up to 75 gpm (up to 17034 L/hr)
PRXF60LV3FS3FS	60 psi, inlet 3" F slip, outlet 3" F slip	60 psi (4.14 bar)	125 psi (8.62 bar)	up to 75 gpm (up to 17034 L/hr)

The PRXF-LV limits downstream pressure to no more than 15 psi (1.03 bar) above regulated pressure during static (no flow) conditions.

Recommended for outdoor use only. Not NSF certified.

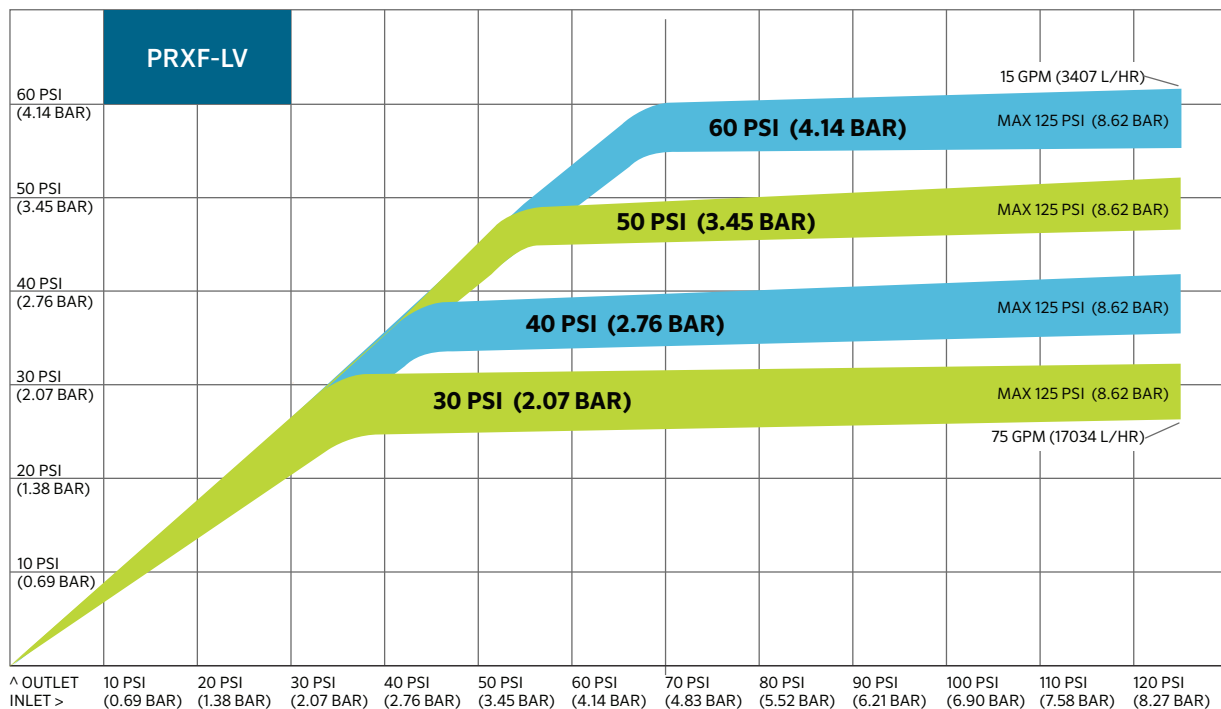

Every pressure regulating extended flow limit valve is designed to operate at a minimum and maximum inlet pressure and a predetermined flow range. This regulation performance curve illustrates how the PRXF-LV will perform within the range of inlet pressures and flows.

The Y-axis shows outlet pressure, and the X-axis shows inlet pressure. In this chart, the band for the 30 psi (2.07 bar) model shows the performance at various flows. At the lowest flow (15 gpm or 3407 L/hr), the regulator will maintain an actual outlet pressure slightly higher than 30 psi (2.07 bar). In contrast, at the highest flow (75 gpm or 17034 L/hr), the actual outlet pressure will be slightly lower than 30 psi (2.07 bar)*.

*Source: Rogers, Shaw, Pragada, & Alam, 2010.

Hunter® | *Agricultural Irrigation*

At Hunter Agricultural Irrigation, our commitment is to continue developing world-class Senninger® irrigation products and providing local support and technical expertise. This results in the most efficient and reliable agricultural irrigation solutions available today.



Steve Abernethy, President of Hunter Agricultural Irrigation

Website senninger.com | **Customer Support** +1-407-877-5655

Domestic Customer Service us-cs@senninger.com | **International Customer Service** intl-cs@senninger.com

FLORIDA HEADQUARTERS

13505 Granville Avenue
Clermont, FL 34711 USA
Tel: +1-407-877-5655

NEBRASKA WAREHOUSE

1713 Holland Drive
Grand Island, NE 68803 USA
Tel: +1-308-381-8558

TEXAS WAREHOUSE

5810 50th Street
Lubbock, TX 79424 USA
Tel: +1 -806-793-3010

BRAZIL

Praça Emilio Marconato
1000 Galpão G-44
Núcleo Residencial Doutor João Aldo Nassif
Jaguariúna - SP CEP 13916-074
Tel: +55-19-3802-1917

© 2024 Hunter Industries Inc., Hunter, the Hunter logo, Senninger, and other marks are trademarks of Hunter Industries Inc., registered in the U.S. and certain other countries. Please recycle.